

Safety Standard Operating Procedures for Cavalry and Mounted Infantry When Maneuvering Around Artillery



The Artillery Reserve Assoc., in an effort to ensure the personal safety of artillerists, cavalry troopers and mounted infantry, has reviewed and adopted the following Safety Standard Operating Procedures for Cavalry and Mounted Infantry.

The SSOP will serve as the "official rules and regulations" regarding mounted units in the proximity of artillery batteries and /or individual artillery pieces positioned on the battlefield when commanded by the Artillery Reserve.

The blank cartridge (powder charge), when ignited in the field piece tube, throws a cone of flame down range from the muzzle of the gun almost 50 yds. . An accidental discharge with an object such as the rammer, the worm or a small solid piece of debris in the tube will throw fragments down range an unpredictable distance. The spent primer is launched upward in a column of flame as the gun is fired and sometimes comes down outside the danger zone. All personnel shall be aware of the dangers associated with being near the gun line or a cannon and remain outside the danger zones if not a member of the Artillery or attached to that service.

All non-artillery personnel, re-enactors and spectators, will maintain a safe distance from the artillery during demonstrations or battle reenactments. The proper safe distances from any gun line or cannon and limber are outlined in the following diagrams.

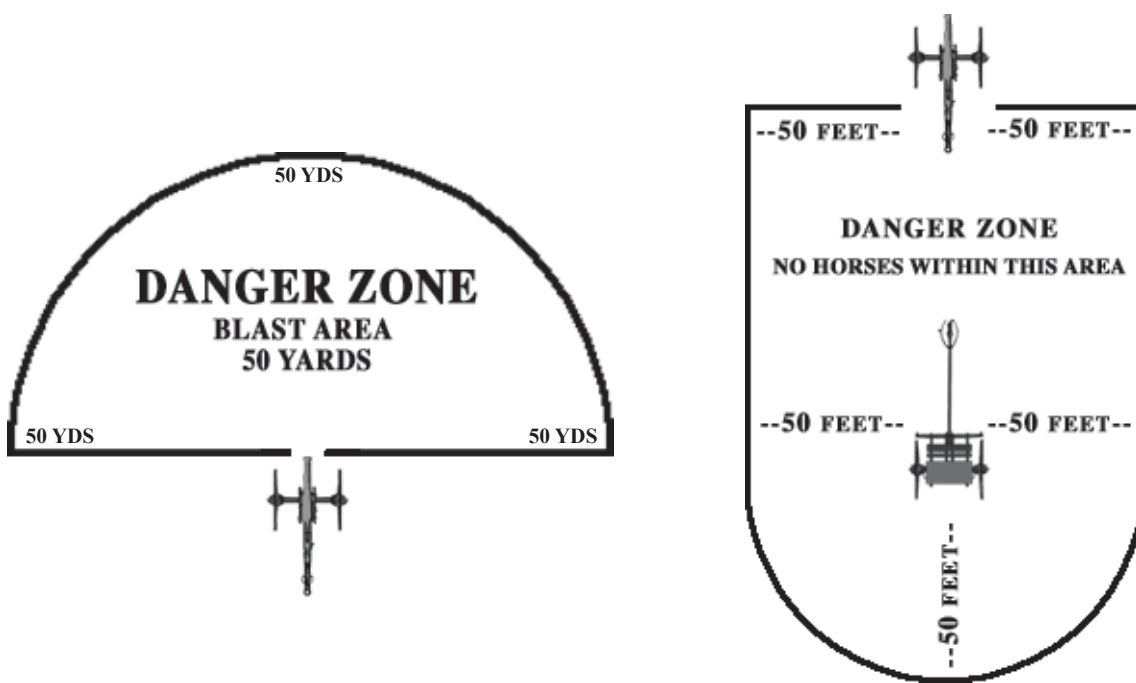

Diagram 1
(Blast Area)

Diagram 2
(Danger Area)

Diagram 1

A 50 yard diameter danger zone will be maintained in front of the gun muzzle in all directions. NO ONE including Artillery personnel will breach this danger zone. The “Blast Area” Danger Zone may be marked by red flags or other identification markers at their outer limits on stationary guns.

Diagram 2

A 50 foot diameter danger zone will be maintained around the limber. Only artillery personnel may occupy this area; all others must request permission from the battery commander.

Discharging of firearms or the smoking of tobacco within the danger area is strictly prohibited. The minimum safe distance to the gun from the sides (gun hubs) is 50 feet.

No Horses, or Non Artillery Personnel shall occupy, walk or ride between the gun and limber without the direct permission from the Battery Commander. Unless scripted prior to battle this perimeter is off limits to all mounted and dismounted personnel.

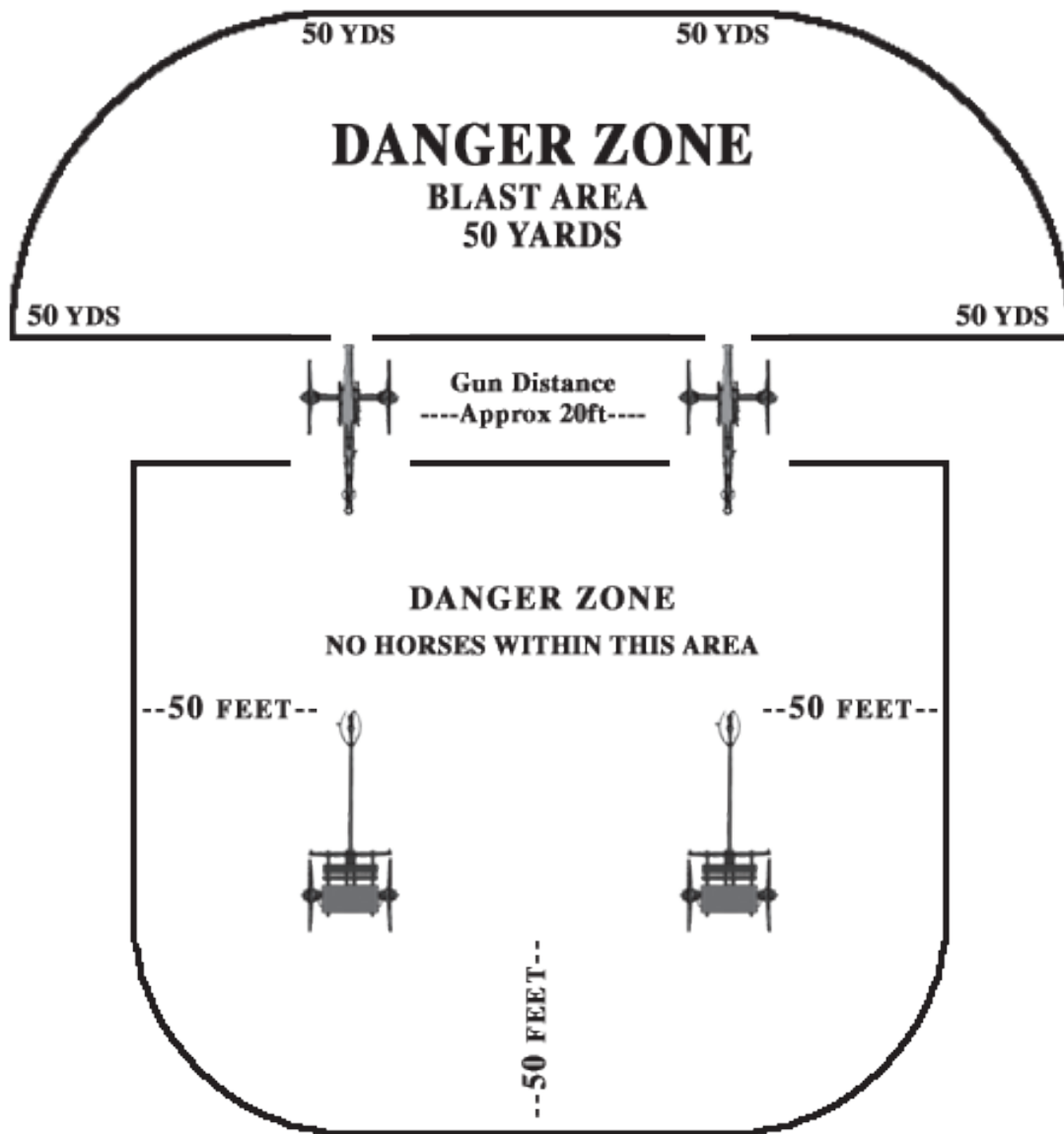

Diagram 3
(Battery Perimeters)

Diagram 3

Danger zones may be marked by red flags or other visual markers at their outer limits. In addition to the markers, the artillery commander may, at times, place personnel outside the danger zones to help ensure that no one crosses into the zones accidentally. All non-artillery personnel must heed any warnings or orders from artillerists regardless of rank, as they are mandated to enforce artillery safety procedures. These members of the artillery shall be regarded as safety officers and will be given the respect due the position. *Note: The distance between guns at an event are determined by scenario and terrain. Because of that, distances between the guns will vary.*

The din and smoke of the battlefield make verbal communication near impossible. The artillery battery relies upon the use of the cannon's implements and hand signs to signal when the cannon is loaded, when it is about to fire, when there is a misfire and when the cannon has been rendered inoperable.

When a battle scenario dictates that mounted and or dismounted personnel shall approach the gun's perimeter, visual signals by artillery personnel should be understood by cavalry or infantry opposing artillery; when and when not to advance on the ordnance. Such signals are outlined in the following diagrams.

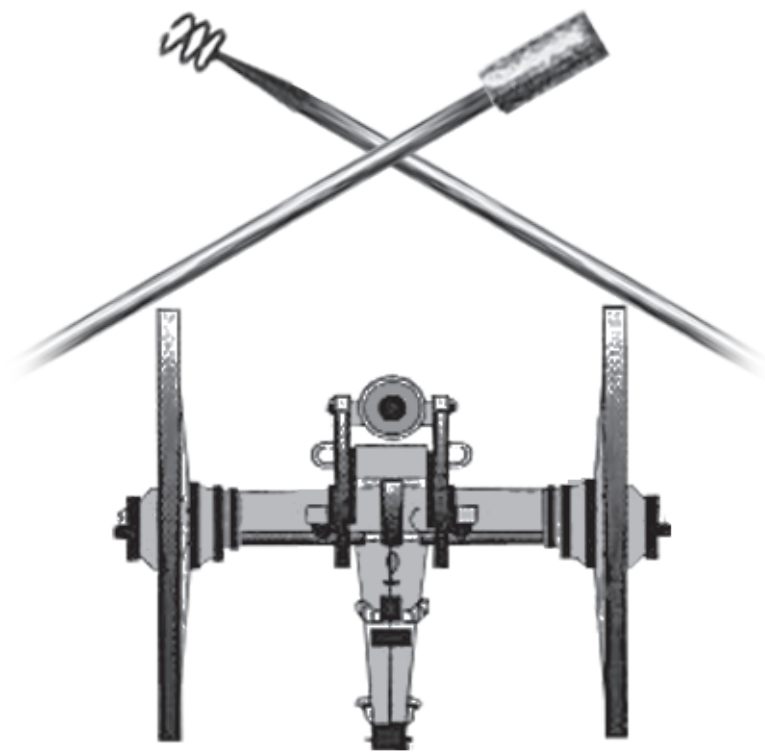

Diagram 4
(failed primer "misfire" signal)

Diagram 4

Crossed rammers or crossed sponge and rammer (Crossed Implements) signal indicates "the primer has failed", and the gun is still "HOT or LOADED" and could fire prematurely. When this signal is given the 50 yard safety "Blast Area" zone is active for this piece of ordnance and must be avoided until the piece is rendered safe by artillery personnel.

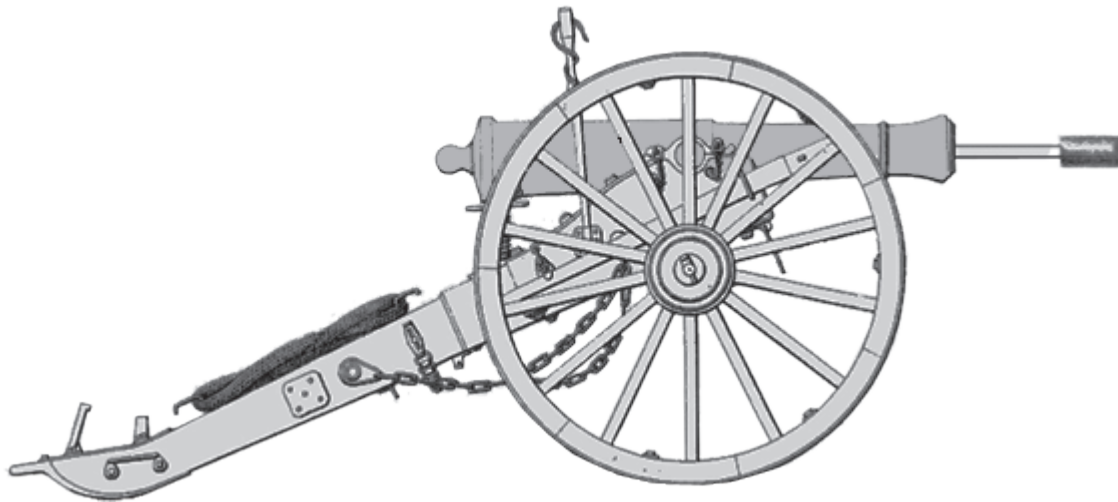

Diagram 5
("spiked" or safe gun)

Diagram 5

The diagram above shows a sponge rammer protruding of the muzzle of the piece in the absence of artillery personnel. This signal indicates the gun is not loaded and is safe to either pass by or approach the piece. If this signal is not indicated, the piece is to be considered dangerous (loaded) and avoided.



Diagram 6
(Cannoneer's inside the Wheels)

Diagram 6

Upon rendering the gun safe to approach, (the sponge rammer in the muzzle) the cannoners, if they do not deployed away from the piece, may position themselves within the wheels, forward and to the rear of the axle for personal safety. This visual movement it is also an indication for cavalry to occupy the front (Blast Area) but not ride pass or around the gun or through an artillery battery. The safety area (Diagram 2) of the limber, however, must be avoided to assure no harm to personnel or damage to property.